

WOODS

SINGLE SPINDLE SLASHERS

woodsequipment.com.au

**QUALITY MACHINES
BUILT FOR EFFICIENCY
AND DURABILITY**

A high-angle, sepia-toned photograph of a tractor with a single spindle slasher attachment working in a field of tall grass. The tractor is positioned in the center-right of the frame, moving towards the left. The slasher attachment is a large, circular, flat-bottomed disc with a central spindle and a chain drive system. The tractor has large, treaded tires and a protective roll-over protection structure (ROPS) around the operator's seat. The background is a dense field of tall grass, and the overall lighting is warm and golden, suggesting late afternoon or early morning.

A SLASHER IS NOT JUST A SLASHER

SINGLE SPINDLE SLASHERS

Table of Contents

Features & Benefits	2
RC Series Slashers	3
RC3.5W	
RC4W	
RC5W	
RC6W	
Specifications Table	4
Industry Leading Brushbull Series	5
Standard Duty Brushbull Series	7
BB48.30W	
BB60.30W	
BB72.30W	
BB84.40W	
Specifications Table	8
Heavy Duty Brushbull Series	9
BB60.50W	
BB72.50W	
BB84.50W	
Specifications Table	10
Upgraded Heavy Duty Brushbull Series	11
BB60.50H	
BB72.50H	
BB84.50H	
Specifications Table	12
Extreme Heavy Duty Brushbull Series	13
BB60.60W	
BB72.60W	
BB84.60W	
Specifications Table	14
Industry Leading Side Throw Series	15
Quick Reference Specifications Table	17



Since 1946 Woods have been manufacturing Woods Equipment in Oregon, Illinois. Woods are American made with American steel - quality machines built to last.

Woods in Australia

TISCA (Tractor Implement Supply Company of Australia Pty Ltd) have been importing Woods equipment for over 15 years. TISCA also manufactures side throw options for all Woods slashers in Australia.

Find a Woods Dealer

Woods Equipment is distributed through a network of authorised dealers. To find your nearest dealer visit us at woodsequipment.com.au or call (07) 5441 5677

So... Why Woods?

About Woods - Exclusive Features	Why Woods?
Made in USA with American Steel	Quality product, quality inputs, made to last
Change blades from above machine	Highest OH&S rating for operators for all slashers
Light hand tools required to change blades	No need for oxy, grinders or rattle guns - change blades roadside
Change blades within minutes - Quick Change Blades system	Reduction in costly downtime
4x stronger blade pin 38mm compared to 19mm bolt on standard slashers	Increased strength of blades when slashing
Greaseable blade pin	Increased longevity out of a set of blades
Built on complete subframe	Deck has increased integrity and durability in all slashing conditions
Stump jumping disc	Protect gearbox, full 360° rotation of blades to minimise impact when slashing
Does not leave a windrow	Clean distribution of material, reduced risk, efficient material management
10-year gearbox warranty	Reliable product backed by leading warranty

A SLASHER IS NOT JUST A SLASHER

WOODS EXCLUSIVE QUICK CHANGE BLADE PIN SYSTEM

INDUSTRY LEADING DESIGN, DURABILITY AND STYLE UNDER THE DECK, TOO!

Woods **Competitor**

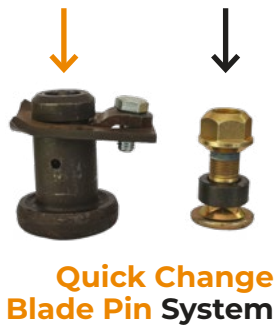

Blade Installation Guide
Grease Nipple Lubricated

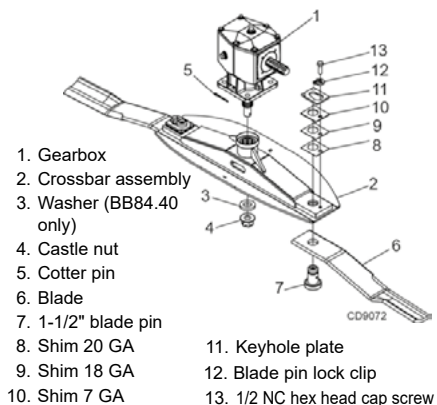

RC Single Spindle Slasher Series

Light Duty Single Spindle Slashers

Woods' RC Series Single Spindle Slasher is the ideal slasher for your compact or sub compact tractor, or if you are looking for a light duty slasher for everyday slashing.



Model shown with standard shielding



Model shown with optional chain shielding



DESIGNED FOR VALUE

An economical slasher for maintaining grass with a cutting capacity of 25mm diameter material. Suitable for tractors with a 15-50 PTO horsepower.

- Four cutting widths to match the size of your job
- Unique smooth sloped decks are easy to maintain and reduce build-up of water and debris
- Stump jumpers are standard on all models for added driveline protection
- High strength steel and quality parts provide dependable service year after year
- Six-year gearbox warranty, one year deck warranty

Tractor PTO HP Range:

15 - 50hp

Models

RC3.5W | 1m (3.5')

RC48.20 | 1.2m (4')

RC60.20 | 1.5m (5')

RC72.20 | 1.8m (6')

"THE WOODS RC SERIES SLASHER IS A SUPERIOR LIGHT DUTY SLASHER. OUR WOODS RC3.5 IS THE ONLY SLASHER THAT FITS BETWEEN OUR ROW WIDTHS IN OUR POLYTUNNELS WITHOUT DAMAGING OUR CROPS. WE RELY ON WOODS EVERY DAY."

Gavin Scurr

Woods Owner, Pinata Farms

SPECIFICATIONS		RC SINGLE-SPINDLE SLASHER SERIES			
MODEL	RC3.5W	RC48.20	RC60.20	RC72.20	
Tractor PTO Horsepower	15hp - 50hp		20hp - 50hp	25hp - 50hp	
Gearbox Horsepower	50hp				
Cutting Width	1.05m (3.5')	1.2m (4')	1.52m (5')	1.83m (6')	
Cutting Capacity	25mm				
Cutting Height Range	50mm - 230mm				
Weight	200kg	220kg	260kg	295kg	
'Quick Change' Blade Pins	No				
Contour Frame Design	Yes				
Hitch	Category 1, 3 point hitch				
Skids	Welded / Bolt on (Optional)				
Slip Clutch Protection	Driveline with slip clutch protection				
Deck Side Depth	176mm				
Stump Jumper	Yes				
Tip Speed	11,460fpm	13,100fpm	13,620fpm	14,340fpm	
Blade Size	12.7mm x 76.2mm				
Tail Wheel	100mm x 380mm laminated tail wheel with 360° rotation				
Shielding	Rubber belt (front), metal plate (back) / Optional chain shielding				
Warranty	6 year limited gearbox warranty; 1 year deck warranty				

WOODS RC SERIES - DURABLE, VERSATILE, AFFORDABLE



Strong, fabricated tail wheel assembly with solid, laminated tyre with 360° rotation.



Breakaway link allows slasher to float and follow terrain for better cut quality.



Optional bolt-on replaceable skid shoes for longer wear.



Optional front and rear chains shielding for added protection from discharged objects.



50hp gearbox with 6-year gearbox warranty.

INDUSTRY LEADING DESIGN

The adjustable drive lift hanger and the quick-hitch compatibility make it easy to attach to your tractor.

A large access window on the top of the deck and our **EXCLUSIVE** greaseable Quick-Change blade pins make blade changes easy, even in the paddock.

A deep deck, large 12.7mm x 101.6mm blades and welded baffle work together, creating a strong suction that lifts, then evenly cuts and distributes large amounts of material.

INDUSTRY LEADING DURABILITY

- The structural integrity of a Woods slasher is in the complete subframe the slasher is built in rather than in the deck skin making the slasher more durable and efficient.
- High-strength steel bumper is 2x thicker than our competitors models, with a Z-channel frame for added durability when backing over tough material.
- New, advanced gearbox seal technology is designed for hard conditions, reduces leaks and downtime and is backed by our ten-year gearbox warranty, which includes the seals.

INDUSTRY LEADING STYLE

Woods was the first to introduce a smooth, sloped deck that sheds debris.

Front corners angle back to give operators more room between the tractor tyre and the cutter.

Adjustable driveline hanger makes it easier to attach, and will stop dirt and water affecting shaft when removed from tractor.

Breakaway link allows slasher to float and follow terrain for a better quality cut.

Corners angle back to give operators more room between the tractor tyre and slasher.

Bolt-on skids protect the deck and are easy to change. Bevelled skids will not gouge the ground.



Smooth sloped deck sheds debris and is easy to clean resulting in less damage to the deck and lower R&M costs.

BB60.30W

WHY ARE WOODS BRUSHBULLS AN INDUSTRY LEADER IN AUSTRALIA?



Quick Change Blade Pins

Quick Change blade pin system allows operator to change blades within a couple of minutes with light hand tools – no oxy required.



Greaseable Blade Pins

Greaseable blade pins allows the blade pin to be greased to get greater longevity out of the blade carrier, reducing repairs and maintenance costs.



Change Blades Above Machine

Change blades efficiently from above the slasher – no need to lift slasher up or for operator to be under the slasher. Reduce OH&S risk and change blades within a couple of minutes.

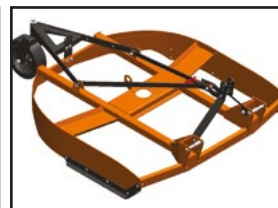

Deck Frame

The structural integrity of a Woods slasher is in the complete subframe the slasher is built in rather than in the deck skin making the slasher more durable and efficient.



Stump Jumper

Woods slashers feature a stump jumper rather than a beam. Stump jumper allows slasher to ride up over objects rather than hitting them with the beam causing damage to tractor and slasher.



New, advanced gearbox seal technology is designed for hard conditions, reduces leaks and downtime and is backed by our ten-year gearbox warranty, which includes the seals.

Greaseable blade pins allows the blade pin to be greased to get greater longevity out of the blade carrier, reducing repairs and maintenance costs.



Change blades efficiently from above the slasher – no need to lift slasher up or for operator to be under the slasher. Reduce OH&S risk and change blades within a couple of minutes.

High-strength steel bumper is 2x thicker than our competitors models, with a Z-channel frame for added durability when backing over tough material.

INDUSTRY LEADING DESIGN, DURABILITY AND STYLE UNDER THE DECK, TOO!



- Rear baffle, standard on all models, concentrates the airflow and ensures cut material is distributed evenly
- The large 12.7mm x 102mm blades and extra deep deck precisely cut large amounts of material
- A beefier, heavy-duty crossbar and 6.35mm steel stump jumper protect the undercarriage from extreme conditions
- The frame is built with full length 75mm by 75mm tubes and channels for extra durability

COUNT ON THE INTEGRITY OF THE BRUSHBULL FRAME

- Stress points are tied to full-length 75mm by 75mm tubes, not on the deck plate, for added stability.
- A full frame design means strength and durability are built into every BrushBull from the frame out.
- The rear bumper is a Z-shaped channel that is two-times thicker than competitive models, adding structural integrity when backing over material.



"WOODS ARE WELL BUILT MACHINES."

Mark Taylor
Orchardist & Woods Owner

Brushbull - Standard Duty

Single Spindle Brushbull Slasher Series

The Woods Standard Duty Single Spindle Slasher Series is perfect for tractors with up to 65 tractor PTO horsepower. With a cutting capacity of 50mm diameter material, the Brushbull Standard Duty Series is ideal for slashing clean paddocks, maintaining fence lines and slashing around sheds.



Tractor PTO HP Range:
25 - 65hp

Models

BB48.30W | 1.22m (4')
BB60.30W | 1.52m (5')

- 65hp slasher gearbox
- Cuts material 50mm diameter thick
- 10-year gearbox warranty, including on the seals
- A 265mm deep deck with 12.7mm x 101.6mm blades and the rear baffling work together to evenly cut and distribute large amounts of material, for a superior cut quality

Tractor PTO HP Range:
30 - 75hp

Models

BB72.30W | 1.83m (6')

- 75hp slasher gearbox
- Cuts material 50mm diameter thick
- 10-year gearbox warranty, including on the seals
- A 265mm deep deck with 12.7mm x 101.6mm blades and the rear baffling work together to evenly cut and distribute large amounts of material, for a superior cut quality

Tractor PTO HP Range:
55 - 90hp

Models

BB84.40W | 2.13m (7')

- 90hp slasher gearbox
- Cuts material 50mm diameter thick
- 10-year gearbox warranty, including on the seals
- A 295mm deep deck with 12.7mm x 101.6mm blades and the rear baffling work together to evenly cut and distribute large amounts of material, for a superior cut quality
- Optional dual tail wheel

SPECIFICATIONS		BRUSHBULL STANDARD DUTY SINGLE SPINDLE SERIES			
MODEL	BB48.30W	BB60.30W	BB72.30W	BB84.40W	
Tractor PTO Horsepower	25hp - 65hp		30hp - 75hp	55hp - 90hp	
Gearbox Horsepower	65hp		75hp	90hp	
Cutting Width	1.2m (4')	1.5m (5')	1.83m (6')	2.13m (7')	
Cutting Capacity	50mm				
Cutting Height Range	25mm - 230mm				
Weight	290kg	340kg	420kg	520kg/580kg (single wheel/dual wheel)	
'Quick Change' Blade Pins	Yes				
Contour Frame Design	Yes				
Hitch	Heavy duty clevis hitch; Cat 1, 3 point hitch			Heavy duty clevis hitch; Cat 1 & 2	
Structural Tubes	Two 75mm x 75mm full length structural tubes – EXCLUSIVE FEATURE				
Tube Bumper/Rear Frame	50mm Z Channel round tube bumper / rear frame – EXCLUSIVE FEATURE				
Skids	Bolt on bevelled				
Slip Clutch Protection	Driveline with slip clutch protection				
Deck Side Depth	265mm			295mm	
Stump Jumper	Yes				
Tip Speed	13,000fpm	14,355fpm	14,963fpm	15,086fpm	
Access Window	Access window on top of deck for easy blade change – EXCLUSIVE FEATURE				
Blade Size	12.7mm x 101.6mm				
Tail Wheel	3 point mounted tail wheel. 100mm x 380mm laminated tail wheel with 360° rotation on bearing hub			3 point mounted tail wheel. 125mm x 400mm laminated tail wheel with 360° rotation on tapered roller bearing hub	
Shielding	Front & Rear chain shielding				
Warranty	10 year limited gearbox warranty; 2 year deck warranty				
Options				Dual tail wheels	

"SINCE PURCHASING A WOODS SLASHER WE DO NOT NEED TO USE OUR MULCHER. A WOODS SLASHER DOES NOT LEAVE A WINDROW, DISTRIBUTES MATERIAL EVENLY AND ALLOWS US TO WORK FASTER THAN WHEN WE WERE USING MULCHERS. THE LOWER OPERATING COSTS AND THE EASE OF OPERATION FOR BOTH THE TRACTOR AND OPERATOR MAKE THE DECISION TO PURCHASE A WOODS SLASHER AN EASY ONE."

Geoff & Andrew

Graziers, Feedlotters & Woods Owners

Brushbull - Heavy Duty

Single Spindle Brushbull Slasher Series

The Woods Heavy Duty Single Spindle Slasher Series is perfect for tractors with up to 150 tractor PTO horsepower. With a cutting capacity of 75mm diameter material, the Brushbull Heavy Duty Series is ideal for slashing paddocks with regrowth, roadways and pastures.



- Three-point hitch: Cat 1 & 2, Cat 2 & 3
- Cuts material up to 75mm diameter
- Ten-year limited gearbox warranty includes the seals
- 150hp slasher gearbox
- A deep 322mm deck, with 12.7mm x 101.6mm blade and rear baffling work together to evenly cut and distribute large amounts of material, for a superior cut quality
- BB84.50W comes standard with dual wheels
- Options: Dual tail wheel on BB72.50W
- Optional: Side Throw and Uprated Shaft

Tractor PTO HP Range:
30 - 150hp

Models

BB60.50W | 1.5m (5')
BB72.50W | 1.83m (6')
BB84.50DW | 2.13m (7')

A SLASHER IS NOT JUST A SLASHER

**"I WOULDN'T BUY ANYTHING ELSE. I AM ACHIEVING A
150% PRODUCTIVITY INCREASE WITH WOODS. CUTTING MORE
GRASS IN LESS TIME USING LESS FUEL."**

Mark Lavery

Contractor & Woods Owner

SPECIFICATIONS		BRUSHBULL HEAVY DUTY SINGLE SPINDLE SERIES		
MODEL	BB60.50W	BB72.50W	BB84.50DW	
Tractor PTO Horsepower	30hp - 150hp		60hp - 150hp	
Gearbox Horsepower	150hp			
Cutting Width	1.5m (5')	1.83m (6')	2.13m (7')	
Cutting Capacity	75mm			
Cutting Height Range	50mm - 300mm			
Weight	550kg	620kg/665kg (single wheel/dual wheel)	770kg	
'Quick Change' Blade Pins	Yes			
Contour Frame Design	Yes			
Deck Coating	Powder Coated / Galvanised			
Hitch	Heavy duty clevis hitch; Cat 1 or 2, 3 point hitch		Cat 2 & 3 clevis	
Structural Tubes	Two 75mm x 75mm full length structural tubes – EXCLUSIVE FEATURE			
Tube Bumper/Rear Frame	50mm Z Channel round tube bumper / rear frame – EXCLUSIVE FEATURE			
Skids	Bolt on bevelled			
Slip Clutch Protection	Driveline with slip clutch protection			
Deck Side Depth	322mm			
Stump Jumper	Yes			
Tip Speed	15,525fpm	15,900fpm	16,000fpm	
Access Window	Access window on top of deck for easy blade change – EXCLUSIVE FEATURE			
Blade Size	12.7mm x 101.6mm			
Tail Wheel	3 point mounted tail wheel. 125mm x 400mm laminated tail wheel with 360° rotation on bearing hub			
Shielding	Front & Rear chain shielding			
Warranty	10 year limited gearbox warranty; 2 year deck warranty			
Options	Galvanised / Side Throw	Galvanised / Side Throw / Dual tail wheels (BB72.50W Only)		



BB72.50W

Brushbull - Uprated Heavy Duty

Single Spindle Brushbull Slasher Series

The Woods Uprated Heavy Duty Single Spindle Slasher Series has a heavier duty W2500 Walterscheid driveline with 4 plate clutch, enabling operator to utilise more tractor PTO horsepower in more rugged conditions for a smoother cut. The Woods Uprated Heavy Duty Single Spindle Slasher is a more durable choice for Councils and contractors needing an extra heavy capacity.



Tractor PTO HP Range:
30 - 150hp

Models

- BB60.50WH | 1.5m (5')**
- BB72.50WH | 1.83m (6')**
- BB84.50DWH | 2.13m (7')**

UPDATED OPTIONS

- Powder coated or Galvanised
- Side throw
- Hydraulic mounted fan
- Road sign rack with 3 signs

- Three-point hitch: Cat 1 & 2, Cat 2 & 3
- Cuts material up to 75mm diameter
- Ten-year limited gearbox warranty includes the seals
- 150hp slasher gearbox
- A deep 322mm deck, with 12.7mm x 101.6mm blade and rear baffling work together to evenly cut and distribute large amounts of material, for a superior cut quality
- Driveline with 4 plate slip clutch protection
- Options: Dual tail wheel on BB72.50H
- BB84.50H comes standard with dual wheels

UPDATED FEATURE ANALYSIS



Four Plate Slip Clutch Protection

A larger output shaft size will withstand greater shocks and has a stronger cutter assembly.



Gearbox Seal Protection

Machined hubs and tight tolerance steel shield will prevent any foreign material affecting the lower seal, ensuring long life out of the gearbox.



Driveline Hanger

Driveline hanger will stop dirt and water affecting the shaft when removed from the tractor.



Large Clearance

Large slasher clearance allows for large volumes of material to be cut without choking and use less horsepower and fuel.



No Windrows

No Woods slasher leaves a windrow, allowing for superior management of pasture and regrowth. Even discharge eliminates the risk of a large piles of material being left behind.

A SLASHER IS NOT JUST A SLASHER

COMPETITION ANALYSIS

Tip Speed

A high tip speed may give a cleaner cut however is less tolerant when hitting rocks as it is more likely to break blades which becomes a risk to personnel and increases repairs and maintenance costs. Woods tip speed is optimised.

Structural Integrity

If there is no structural subframe to increase integrity of the slasher then the deck needs to be thicker which will affect the efficiency of the cut for the tractor. Units without a full subframe will need to have heavier plate for integrity which is harder on the tractor to lift and control. The Woods structural subframe moves the stress points to the frame rather than the heavy skin.

Blade Carrier

With a beam as the blade carrier, there are large shocks transmitted to the gearbox and the blades can get wedged in the beams. A stump jumper on a Woods slasher allows for less shocks to the gearbox and the blades can swing 360° upon impact.

SPECIFICATIONS

BRUSHBULL UPATED HEAVY DUTY SINGLE SPINDLE SERIES

MODEL	BB60.50WH	BB72.50WH	BB84.50DWH
Tractor PTO Horsepower	30hp - 150hp		60hp - 150hp
Gearbox Horsepower	150hp		
Cutting Width	1.5m (5')	1.83m (6')	2.13m (7')
Cutting Capacity	75mm		
Cutting Height Range	50mm - 300mm		
Weight	550kg	620kg/665kg (single wheel/dual wheel)	770kg
'Quick Change' Blade Pins	Yes		
Contour Frame Design	Yes		
Hitch	Heavy duty clevis hitch; Cat 1 or 2, 3 point hitch		Cat 2 & 3 clevis
Structural Tubes	Two 75mm x 75mm full length structural tubes – EXCLUSIVE FEATURE		
Tube Bumper/Rear Frame	50mm Z Channel round tube bumper / rear frame – EXCLUSIVE FEATURE		
Skids	Bolt on bevelled		
Slip Clutch Protection	W2500 Series driveline with 4 plate slip clutch protection		
Deck Side Depth	322mm		
Stump Jumper	Yes		
Tip Speed	15,525fpm	15,900fpm	16,000fpm
Access Window	Access window on top of deck for easy blade change – EXCLUSIVE FEATURE		
Blade Size	12.7mm x 101.6mm		
Tail Wheel	3 point mounted tail wheel. 125mm x 400mm laminated tail wheel with 360° rotation on bearing hub (Dual tail wheels standard on BB84.50H)		
Shielding	Front & Rear chain shielding		
Warranty	10 year limited gearbox warranty; 2 year deck warranty		
Options	Hydraulic Mounted Fan / Galvanised / Road Sign Rack with 3 Signs / Side Throw / Dual tail wheels (BB72.50H Only)		

Brushbull - Extreme Heavy Duty

Single Spindle Brushbull Slasher Series

The Woods Extreme Heavy-Duty Single Spindle Slasher Series is perfect for tractors with up to 210 tractor PTO horsepower. With a cutting capacity of 100mm diameter material, the Brushbull Extreme Heavy-Duty Series is ideal for regrowth, rough terrain and contractors.



- Galvanised finish only
- Adjustable skids
- Three-point hitch: Cat 1 & 2, Cat 2 & 3
- Cuts material up to 100mm diameter
- Ten-year limited gearbox warranty includes the seals
- 75mm gearbox output shaft
- 210hp slasher gearbox
- Driveline with 4 plate slip clutch protection
- BB84.60W comes standard with dual wheels

Tractor PTO HP Range:
50 - 210hp

Models

BB72.60W | 1.83m (6')
BB84.60DW | 2.13m (7')



SPECIFICATIONS			BRUSHBULL EXTREME HEAVY DUTY SINGLE SPINDLE SERIES	
MODEL	BB72.60DW		BB84.60DW	
Tractor PTO Horsepower	50hp - 210hp		75hp - 210hp	
Gearbox Horsepower	210hp			
Cutting Width	1.83m (6')		2.13m (7')	
Cutting Capacity	100mm			
Cutting Height Range	50mm - 300mm			
Weight	840kg		995kg	
'Quick Change' Blade Pins	Yes			
Contour Frame Design	Yes			
Hitch	Extra heavy duty clevis hitch points; Cat 1 & 2		Extra heavy duty clevis hitch points; Cat 2 & 3	
Structural Tubes	Two 75mm x 75mm full length structural tubes – EXCLUSIVE FEATURE			
Tube Bumper/Rear Frame	50mm Z Channel round tube bumper / rear frame – EXCLUSIVE FEATURE			
Skids	Adjustable bolt on bevelled skids			
Slip Clutch Protection	W2500 Series driveline with 4 plate slip clutch protection			
Deck Side Depth	322mm			
Stump Jumper	Yes			
Tip Speed	13,950fpm		14,250fpm	
Access Window	Access window on top of deck for easy blade change – EXCLUSIVE FEATURE			
Blade Size	12.7mm x 101.6mm			
Tail Wheel	3 point mounted tail wheel. 125mm x 400mm laminated tail wheel with 360° rotation on tapered roller bearing hub (Dual tail wheels standard on BB84.60W)			
Shielding	Front & Rear chain shielding			
Warranty	10 year limited gearbox warranty; 2 year deck warranty			
Options	Side Throw / Dual tail wheels (BB72.60W Only)			

A SLASHER IS NOT JUST A SLASHER

Side Throw Series

Single Spindle Side Throw Series

The Woods Side Throw Single Spindle Slasher Series is perfect for any side throw applications, particularly in orchards where the control of discharge aids mulching under trees.

Tried and tested in orchards and paddocks across Australia, the Woods Side Throw slasher is designed to work and its results make it the industry leader for side throw slashers.

- Material won't choke up under machine
- Controlled discharge via adjustable chute
- Throw adjustable to suit variety of row widths
- Won't gauge ground

An adjustable flap on the discharge chute ensures the controlled distribution of material where you want it, such as under trees.

Bevelled chute to protect fruit on trees in orchard.



Smooth sloped deck sheds debris and is easy to clean resulting in less damage to the deck and lower R&M costs.



BB72.50W

Side Throw available on all models

WHY ARE WOODS SIDE THROWS INDUSTRY LEADERS IN AUSTRALIA?



Quick Change Blade Pins

Quick Change blade pin system allows operator to change blades efficiently from above machine within a couple of minutes with light hand tools – no oxy required.



High Throw Blade

The high throw blade will discharge material with total clearance so material does not block up machine.



Adjustable Flap

An adjustable flap on the discharge chute ensures the controlled distribution of material where you want it, such as under trees.



Air Vents

Air vents assist in airflow to ensure complete discharge of product.



Anti-Scalp Wheel - Optional

Optional height adjustable anti-scalp wheel available to further stabilise machine and prevent gauging.



New, advanced gearbox seal technology is designed for hard conditions, reduces leaks and downtime and is backed by our ten-year gearbox warranty, which includes the seals.



Change blades efficiently from above the slasher – no need to lift slasher up or for operator to be under the slasher. Reduce OH&S risk and change blades within a couple of minutes.

The high throw blade will discharge material with total clearance so material does not block up machine.

Bevelled skids will not gouge the ground.



BENEFITS OF A WOODS SIDE THROW SLASHER

- Adjustable flap controls discharge to allow mulching under trees and increase efficiency of production and reduce erosion
- Air vent and high lift blades ensure complete discharge of material
- Deck design ensures slasher will not leave a windrow for efficient grass management

A SLASHER IS NOT JUST A SLASHER

"EVEN WHEN SLASHING IN HEAVY MATERIAL NOTHING IS LEFT BEHIND, GIVING MY ORCHARD A MOWER FINISH AND NICELY DISCHARGING MATERIAL UNDER MY TREES."

Mark Taylor

Orchardist & Woods Owner

SPECIFICATIONS
SINO

MODEL	RC3.5W	RC48.20	RC60.20	RC72.20	BB48.30W	BB60
Tractor PTO Horsepower	15hp - 50hp		20hp - 50hp	25hp - 50hp	25hp - 65hp	
Gearbox Horsepower	50hp				65hp	
Cutting Width	1.05m (3.5')	1.2m (4')	1.52m (5')	1.83m (6')	1.2m (4')	1.5m
Cutting Capacity	25mm					
Cutting Height Range	50mm - 230mm					
Weight	200kg	220kg	260kg	295kg	290kg	340
'Quick Change' Blade Pins	No					
Contour Frame Design						
Deck Coating	Powder Coated					
Hitch	Category 1, 3 point hitch				Heavy duty clevis hitch	
Structural Tubes	N/A					
Tube Bumper/Rear Frame	N/A					
Skids	Welded / Bolt on (Optional)					
Slip Clutch Protection	Driveline with slip clutch protection					
Deck Side Depth	176mm				265mm	
Stump Jumper						
Tip Speed	11,460fpm	13,100fpm	13,620fpm	14,340fpm	13,000fpm	14,350
Access Window	Yes - Access for spanners					
Blade Size	12.7mm x 76.2mm					
Tail Wheel	100mm x 380mm laminated tail wheel with 360° rotation				3 point mounted tail wheel with laminated tail wheel with hu	
Shielding	Rubber belt (front), metal plate (back) / Optional chain shielding					
Warranty	6 year limited gearbox warranty; 1 year deck warranty					
Options						

GLE-SPINDLE SLASHER SERIES

BB72.30W	BB72.30W	BB84.40W	BB60.50W	BB72.50W	BB84.50DW	BB72.60DW	BB84.60DW
	30hp - 75hp	55hp - 90hp	30hp - 150hp		60hp - 150hp	50hp - 210hp	75hp - 210hp
	75hp	90hp	150hp			210hp	
Length (5')	1.83m (6')	2.1m (7')	1.5m (5')	1.83m (6')	2.13m (7')	1.83m (6')	2.13m (7')
50mm			75mm			100mm	
25mm - 230mm			50mm - 300mm				
Weight (kg)	420kg	520kg/580kg (single wheel/ dual wheel)	550kg	620kg/665kg (single wheel/ dual wheel)	770kg	840kg	995kg

Yes

Yes

Powder Coated / Galvanised

Galvanised

Hitch; Cat 1, 3 point hitch

Heavy duty clevis hitch; Cat 1 & 2

Heavy duty clevis hitch; Cat 1 or 2, 3 point hitch

Cat 2 & 3 clevis

Extra heavy duty clevis hitch points; Cat 1 & 2

Extra heavy duty clevis hitch points; Cat 2 & 3

Two 75mm x 75mm full length structural tubes – **EXCLUSIVE FEATURE**

50mm Z Channel round tube bumper / rear frame – **EXCLUSIVE FEATURE**

Bolt on bevelled

Adjustable bolt on bevelled skids

Driveline with slip clutch protection
Optional Upgraded: W2500 Series driveline with 4 plate slip clutch protection

W2500 Series driveline with 4 plate slip clutch protection

mm

295mm

322mm

Yes

rpm

14,963rpm

15,086rpm

15,525rpm

15,900rpm

16,000rpm

13,950rpm

14,250rpm

Access window on top of deck for easy blade change – **EXCLUSIVE FEATURE**

12.7mm x 101.6mm

Wheel. 100mm x 380mm
360° rotation on bearing hub

3 point mounted tail wheel. 125mm x 400mm laminated tail wheel with 360° rotation on tapered roller bearing hub (Dual tail wheels standard on BB84.50W & BB84.60W)

Front & Rear chain shielding

10 year limited gearbox warranty; 2 year deck warranty

Dual tail wheels

Galvanised / Side Throw

Galvanised / Side Throw / Dual tail wheels (BB72.50W Only)

Side Throw / Dual tail wheels (BB72.60W Only)



1137 Nambour Connection Rd, Parklands QLD 4560

(07) 5441 5677

woodsequipment.com.au
tisca.com.au

WOODS

Warning! Some images may show safety shields removed to provide a better view. Equipment should never be operated with any safety shield removed. Some machines in this brochure may be shown with optional equipment. Always operate machines in accordance with supplied operator's manuals. ©2024 Woods Equipment Company. All rights reserved. WOODS and Woods logo are trademarks of Woods Equipment Company. All other trademarks, trade names, or service marks not owned by Woods Equipment Company that appear in this brochure are the property of their respective companies or mark holders. Specifications subject to change without notice.